

The Classic Dairy Valve

D10 and D11 Plug Valves

Application

The bonded rubber or stainless steel plug valves are used in food and chemical industries and in other installations where a sanitary closing device with minimum pressure drop is required. D10 and D11 plug valves are designed for quick and easy operation. The D10 is a two-way valve, and the D11 is a three-way valve.

Standard Design

The plug valves are made of stainless steel AISI 304. They are produced with a strong, rigid body made from drop forged homogeneous material, and the plug is rubber coated. An optional chrome plated and lapped metal plug is available. The plug valves may be supplied with weld connections, clamps or threaded connections.

Materials

Steel parts AISI 304
 Finish ≤ 32 RA
 Rubber parts Buna (N)

Technical data

Maximum working pressure (68° F) 25 PSI
 Maximum test pressure (68° F) 25 PSI
 Maximum temperature 100° F
 Minimum temperature -4° F

Ordering

Please state the following when ordering:

- Connections
 Tri-Clamp®, Bevel Seat, weld
- Type
 Straight-through valve D10, three-way valve D11, tank outlet valve D10F and D10FL legal tank pasteurization valve
- Plug
 Bonded rubber (Buna) or stainless steel. D10FL only available with stainless steel plug
- Size
 Following sizes are available: 1-inch, 1.5-inch, 2-inch, 2.5-inch, 3-inch



D10 and D11 Plug Valves

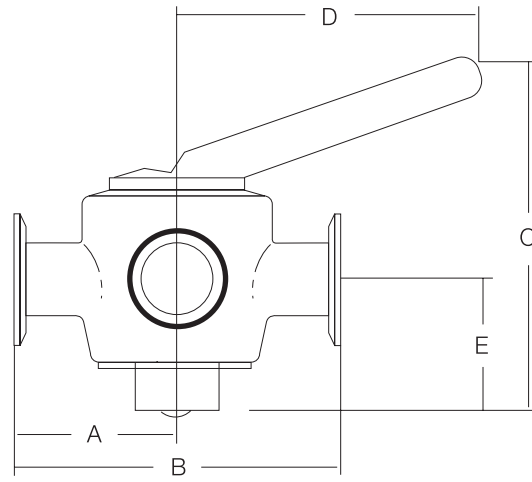
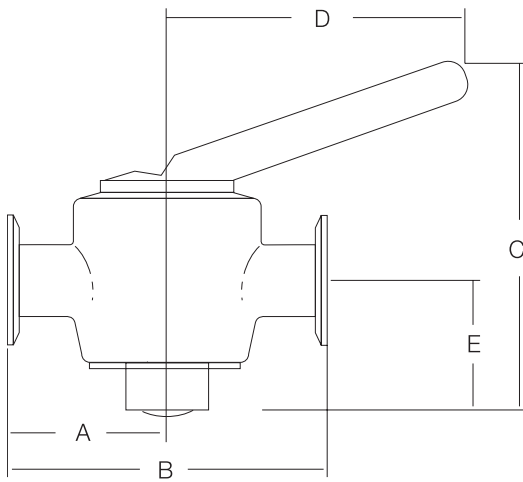

Dimensions Tri-Clamp® connections

Size (Tube OD)		A		B		C		D		E		Approx. Wt.	
inch	mm	inch	mm	inch	mm	inch	mm	inch	mm	inch	mm	lb	kg
1½	38.1	22 ⁹ / ₃₂	73.8	5 ¹³ / ₁₆	147.6	7	177.8	5 ⁵ / ₈	142.9	2½	63.5	9.50	4.30
2	50.8	31 ³ / ₃₂	86.5	6 ¹³ / ₁₆	173.0	7 ⁵ / ₈	193.7	5 ⁵ / ₈	142.9	2 ⁷ / ₈	73.0	15.50	7.03
2½	63.5	4 ¹ / ₈	104.8	8¼	209.6	8¾	222.3	6¼	158.8	3½	88.9	25.50	11.56
3	76.2	42 ³ / ₃₂	119.9	9 ⁷ / ₁₆	239.7	9¾	247.7	7¼	184.2	3¾	95.3	36.00	16.32

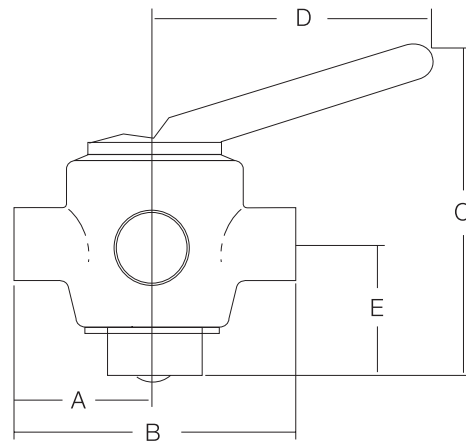
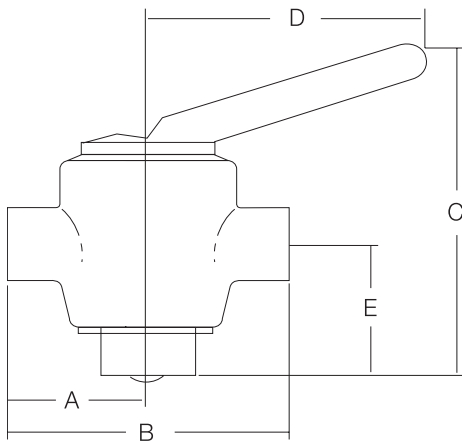

Dimensions Weld connections

Size (Tube OD)		A		B		C		D		E		Approx. Wt.	
inch	mm	inch	mm	inch	mm	inch	mm	inch	mm	inch	mm	lb	kg
1½	38.1	22 ³ / ₃₂	69.1	5 ⁷ / ₁₆	138.1	6 ⁷ / ₈	177.8	5 ⁵ / ₈	142.9	2½	63.5	9.50	4.30
2	50.8	3 ³ / ₁₆	81.0	6 ³ / ₈	161.9	7 ⁵ / ₈	193.7	5 ⁵ / ₈	142.9	2 ⁷ / ₈	73.0	15.50	7.03
2½	63.5	4 ⁷ / ₈	123.8	7¾	196.9	8 ⁵ / ₈	222.3	6¼	158.8	3½	88.9	25.50	11.56
3	76.2	4 ¹⁵ / ₃₂	113.5	8 ¹⁵ / ₁₆	227.0	9¾	247.7	7¼	184.2	3¾	95.3	36.00	16.32

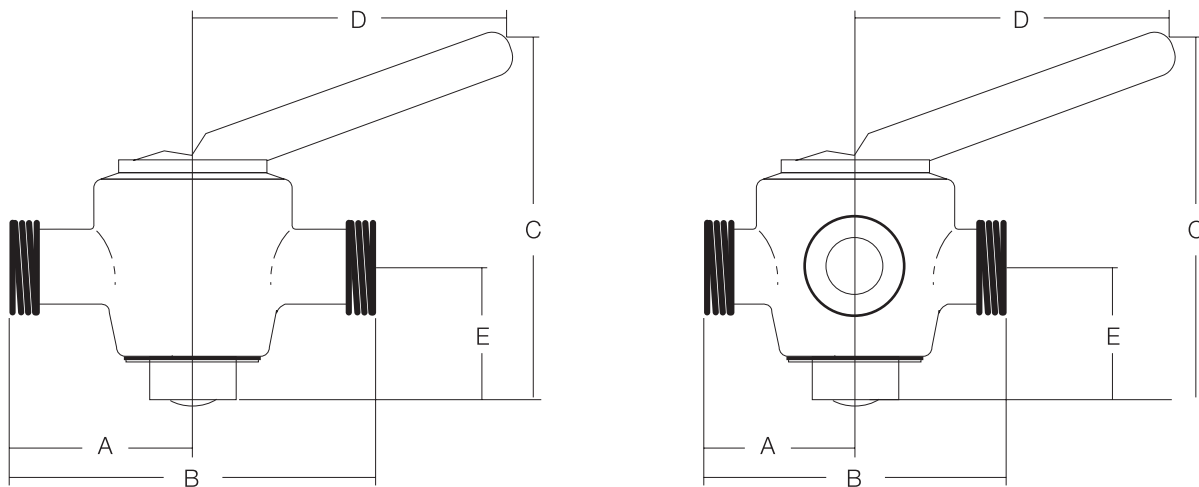

Dimensions Bevel Seat connections

Size (Tube OD)		A		B		C		D		E		Approx. Wt.	
inch	mm	inch	mm	inch	mm	inch	mm	inch	mm	inch	mm	lb	kg
1½	38.1	2 ²⁹ / ₃₂	73.8	5 ¹³ / ₁₆	147.6	6 ⁷ / ₈	174.6	5 ⁵ / ₈	142.9	2½	63.5	9.50	4.31
2	50.8	3 ¹³ / ₃₂	86.5	6 ¹³ / ₁₆	173.0	7 ⁵ / ₈	193.7	5 ⁵ / ₈	142.9	2 ⁷ / ₈	73.0	15.50	7.03
2½	63.5	4 ¹ / ₈	104.8	8¼	209.6	8 ⁵ / ₈	219.1	6¼	158.8	3½	88.9	25.50	11.56
3	76.2	4 ²³ / ₃₂	119.9	9 ⁷ / ₁₆	239.7	9¾	247.3	7¼	184.2	3¾	93.7	36.00	16.33

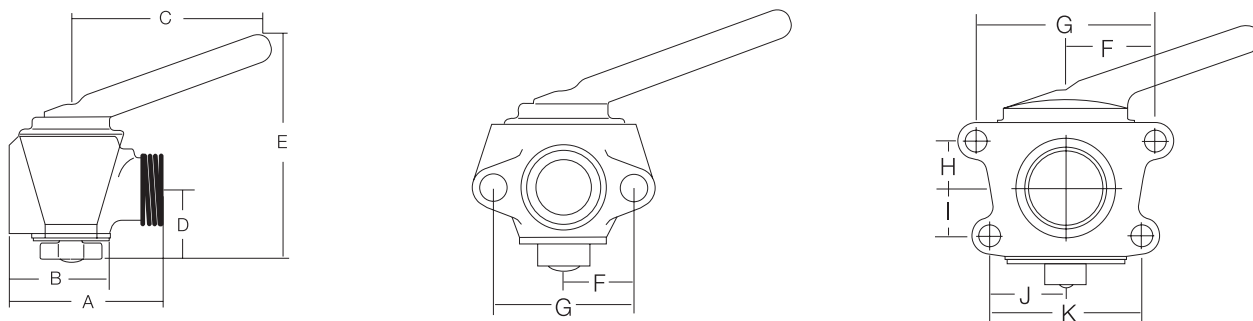

Dimensions (inches) Plug Valve Tank - D10F and D10FL

Size (Tube OD)	A	B	C	D	E	F	G	H	I	J	K	Hole Size	Approx. Wt.	
1½	4 ⁵ / ₁₆	3 ¹ / ₈	5 ⁵ / ₈	2 ³ / ₈	6¾	1 ²³ / ₃₂	3 ⁷ / ₁₆	--	--	--	--	9/16	9.50	4.30
2	5 ⁷ / ₁₆	4 ¹ / ₈	5 ⁵ / ₈	2¾	7½	2 ¹ / ₈	4¼	--	--	--	--	9/16	15.50	7.03
2½	6¾	4 ⁵ / ₈	6¼	3½	8¾	2 ⁵ / ₈	5¼	1 ⁵ / ₁₆	1½	2½	5	9/16	25.50	11.56
3	8	4¾	7¼	3¾	9¾	3 ⁵ / ₁₆	6 ⁵ / ₈	1¾	1¾	2 ¹³ / ₁₆	5 ⁵ / ₈	11/16	36.00	16.32

Dimensions (mm) Plug Valve Tank - D10F and D10FL

Size (Tube OD)	A	B	C	D	E	F	G	H	I	J	K	Hole Size	Approx. Wt.	
1½	109.5	79.4	142.9	60.3	171.5	43.7	87.3	--	--	--	--	14.3	9.5	4.30
2	138.1	104.8	142.9	69.9	190.5	54.0	108.0	--	--	--	--	14.3	15.5	7.03
2½	171.5	117.5	158.8	88.1	222.3	66.7	133.4	33.3	38.1	63.5	127.0	14.3	25.5	11.56
3	203.2	120.7	184.2	95.3	247.7	84.1	168.3	44.5	44.5	71.4	142.9	17.5	36.0	16.32